

ROLL.C4M3 - ROLL.CR4M3 ROLL.C4M3PB - ROLL.CR4M3PB

		ROLL.C4M3 ROLL.C4M3PB	ROLL.CR4M3 ROLL.CR4M3PB
1	2840.17	1	1
2	2092.09		1
3	2092.10		1
4	2092.11		2
5	CHRONO.C4K2		1
6	SER.GL10	4	4
7	ROLL3-01	1	1
8	ROLL3-02	4	4
9	ROLL3-70R2	3	3
10	ROLL3-140R2	1	1
11	ROLL3-05	1	

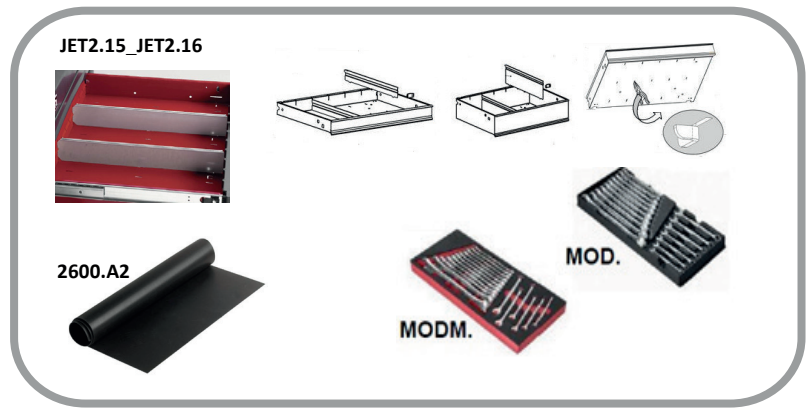
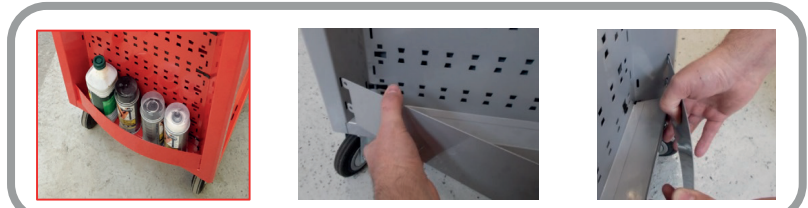
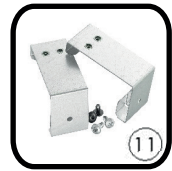
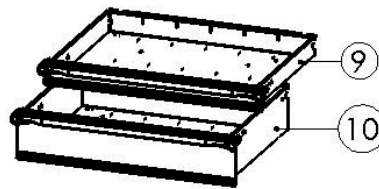
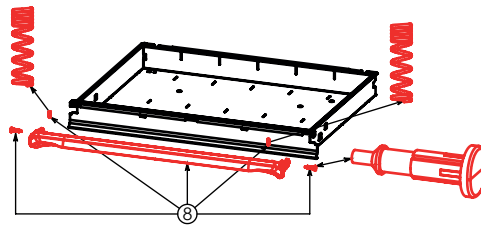
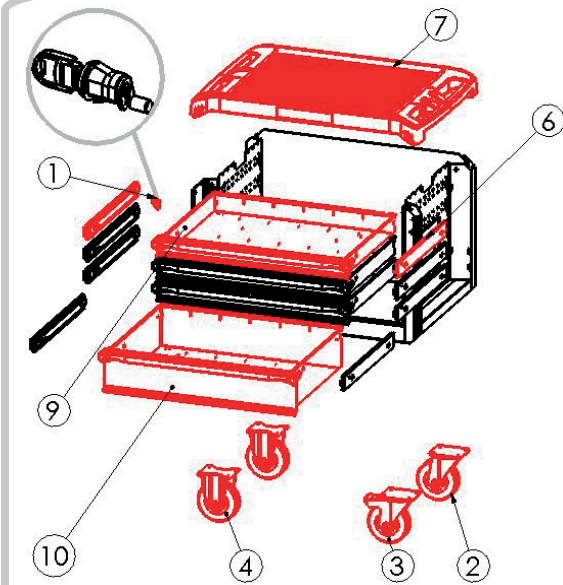

ROLL.C4M3 - ROLL.CR4M3 ROLL.C4M3PB - ROLL.CR4M3PB

Assembly of the chest box on the trolley Montage du coffre sur la servante

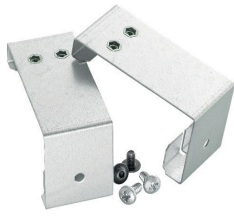

X2

X2

1 - Remove the last drawer of the chest box / Enlever le dernier tiroir du coffre



a - Lower the black clip of the right-hand runner and lift on the left-hand side.
b - Pull out the drawer.

a - Baisser le clip noir de la glissière côté droit et lever le côté gauche.
b - Tirer le tiroir.

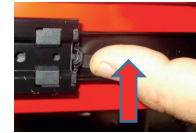

Slide left
Glissière gauche



Slide right
Glissière droite

2 - Position the 2 metal parts first and then the chest box / Positionner les 2 pièces métal puis le coffre sur la servante

2.1



2.2



2.3



3 - Fasten the chest box on the trolley from the inside / Fixer le coffre sur la servante de l'intérieur

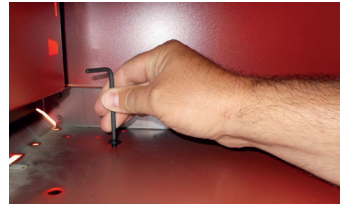

Position of the screw
Position de la vis

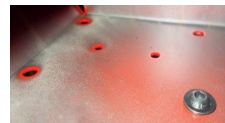

4 - Fasten the parts to the back of the trolley / Fixer les pièces à l'arrière de la servante



Begin with a screw-gun
Commencer avec une visseuse à batterie



Finish with a screwdriver
Terminer avec un tournevis



FACOM S.A.S - 6/8 rue Gustave Eiffel - 91420 MORANGIS - France
Tel: 01 64 54 45 45 Fax: 01 69 09 60 93 www.facom.com

NU-ROLL.C4M3/ROLL.CR4M3_1116